

TOWN CREEK MIDDLE SCHOOL

6370 LAKE PARK DRIVE SE
WINNABOW, NC 28479

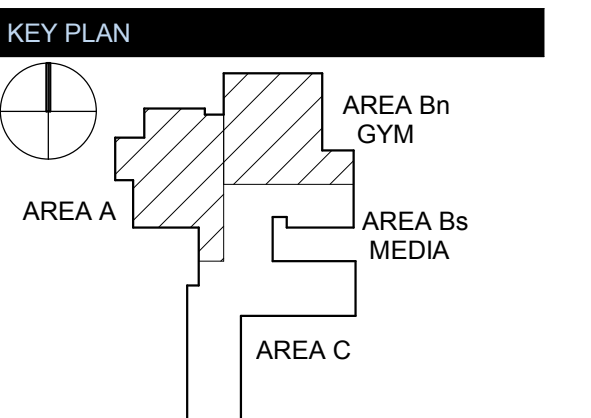

| No. | Description | Date |
|-----|-------------|-----------|
| 1 | Addendum #1 | 6-7-2018 |
| 2 | Addendum #2 | 6-19-2018 |

ISSUED: CONSTRUCTION DOCUMENTS

DATE: 05/24/2018

SCALE: 3" = 1'-0"

SHEET NAME: EXTERIOR PLAN DETAILS

SHEET NUMBER:

A-513

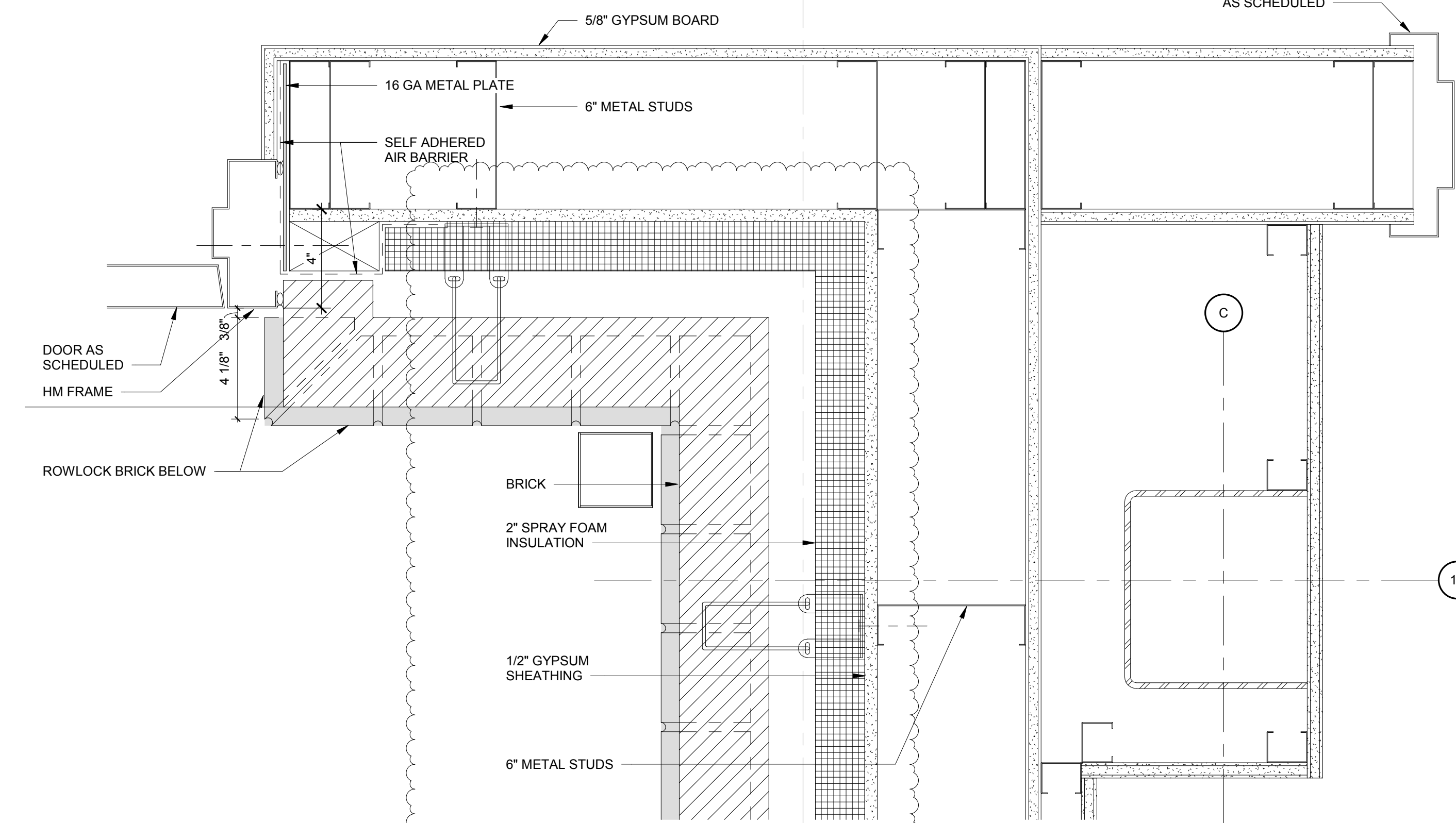
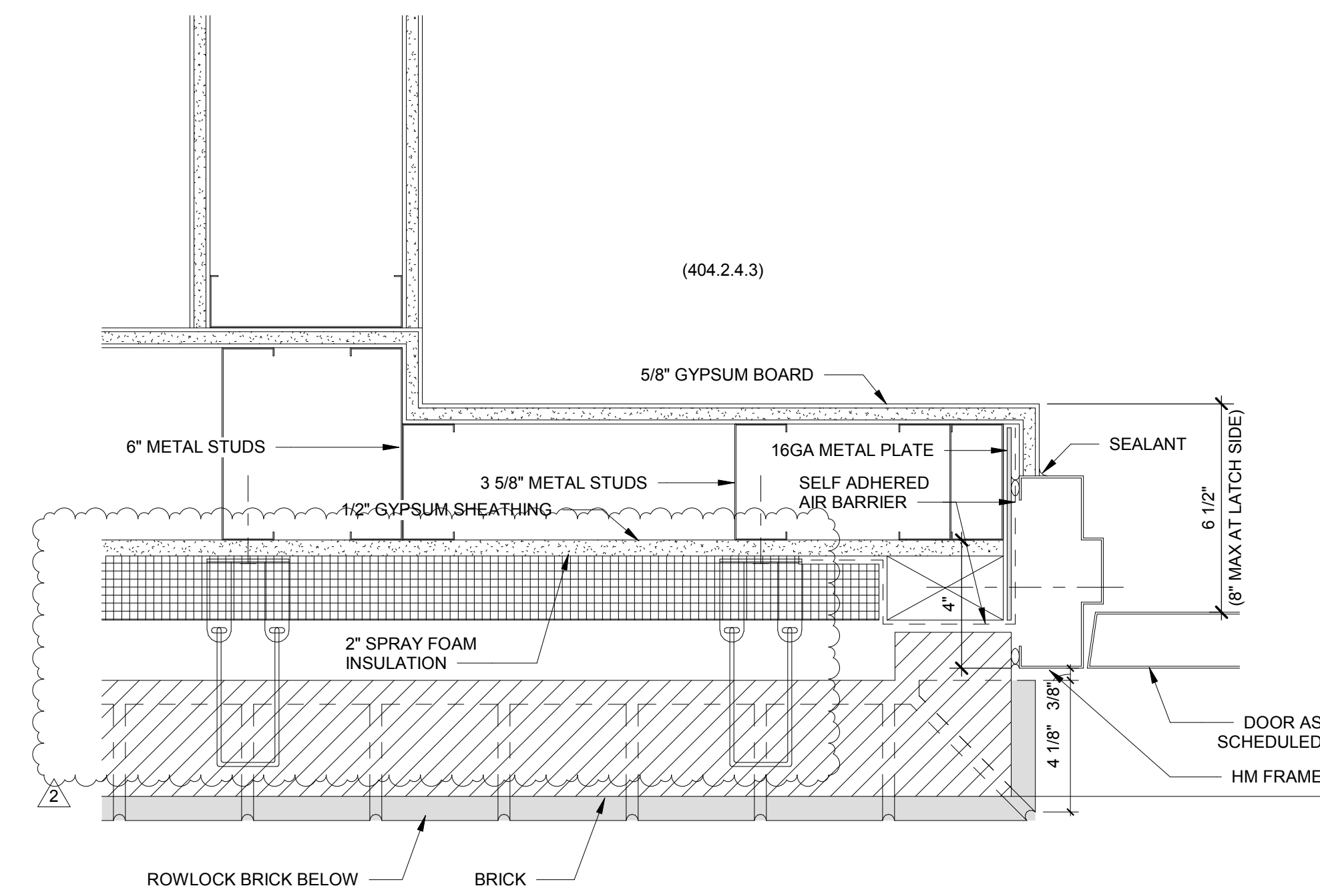

PLAN DETAIL AT B-11 (J1)
3" = 1'-0"

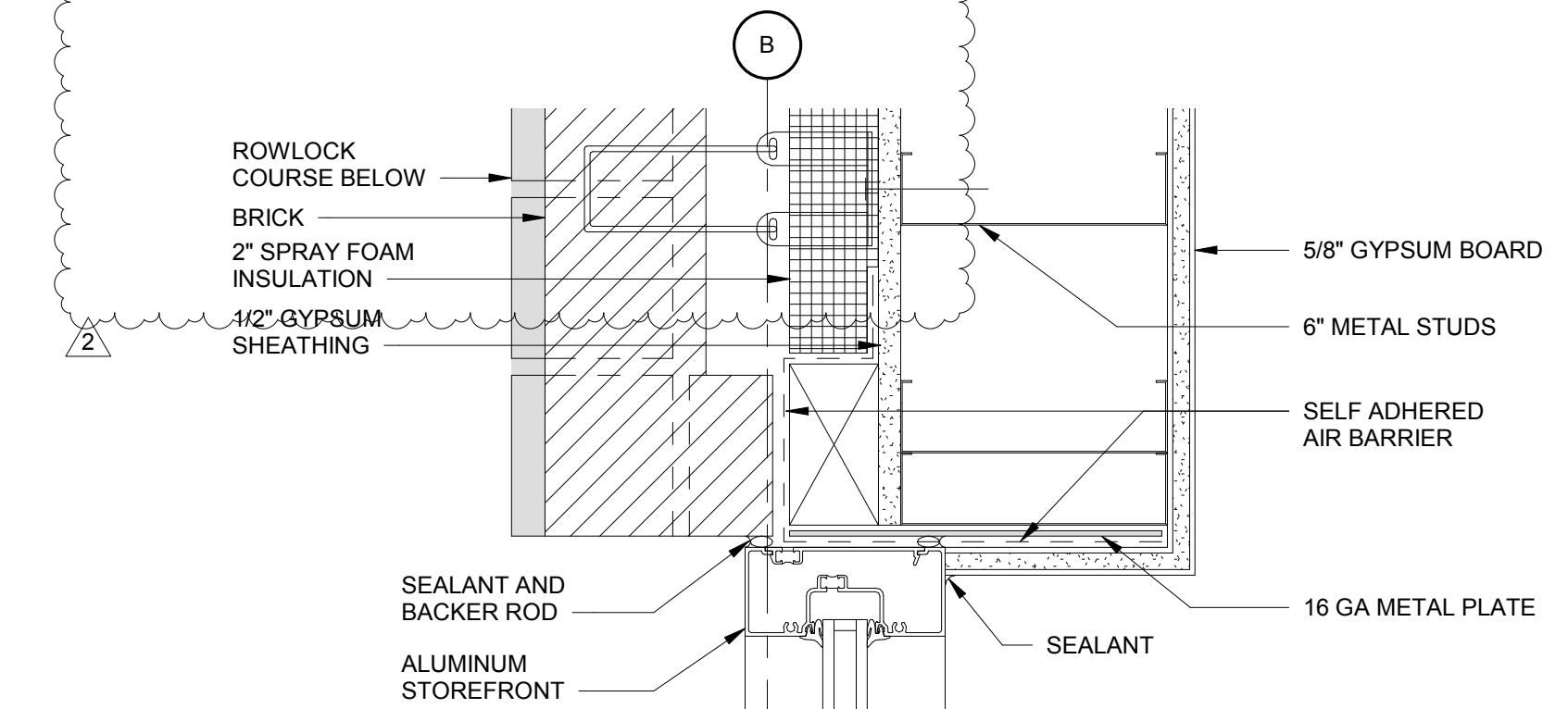

DINING STOREFRONT PLAN DETAIL ALONG B (F1)
3" = 1'-0"

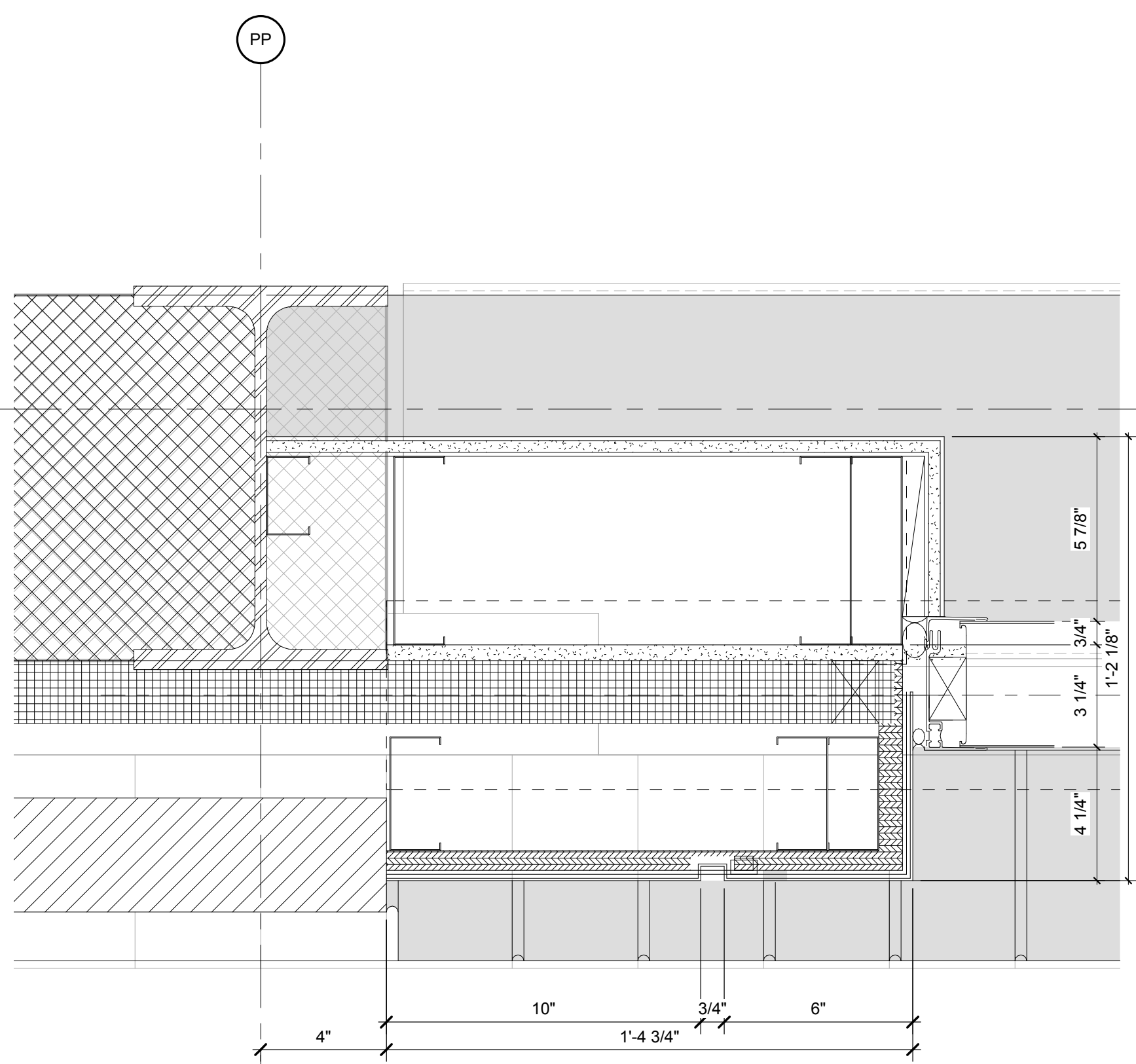

KALWALL M PLAN DETAIL (A7)
3" = 1'-0"

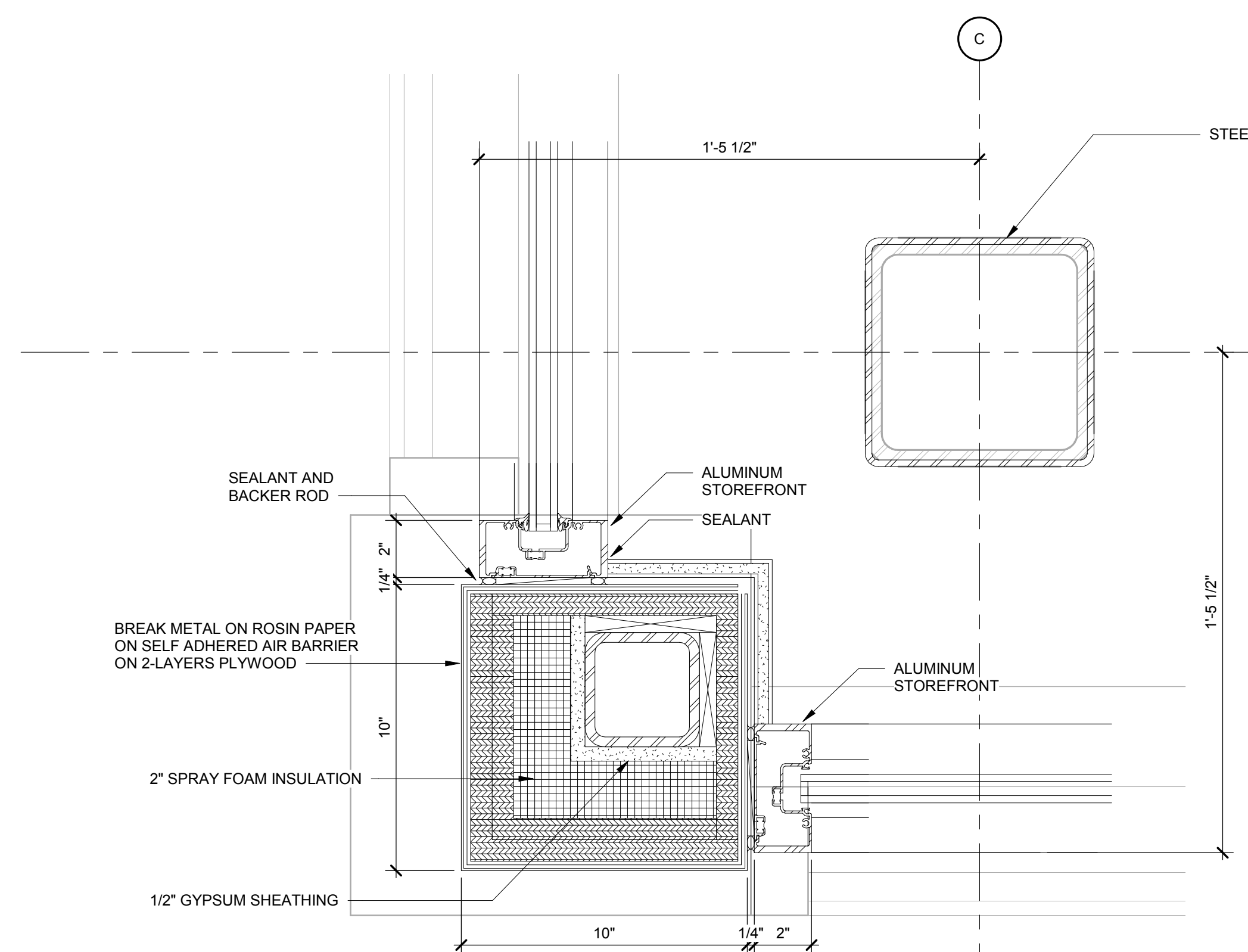

DINING STOREFRONT PLAN DETAIL ALONG C AT 21 (A1)
3" = 1'-0"

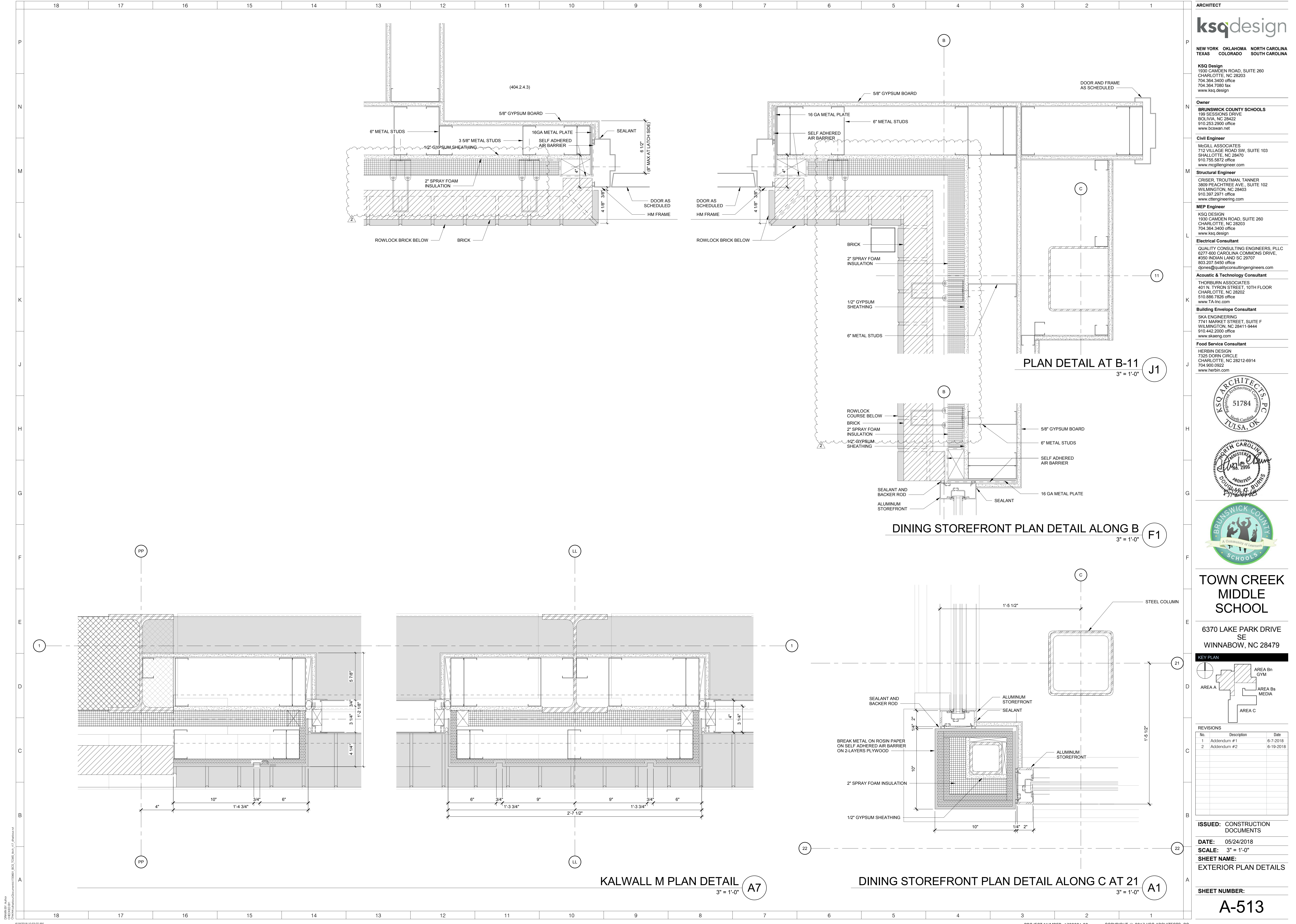

6/18/2018 10:53:02 AM